

CWT-12-__ Standard Features

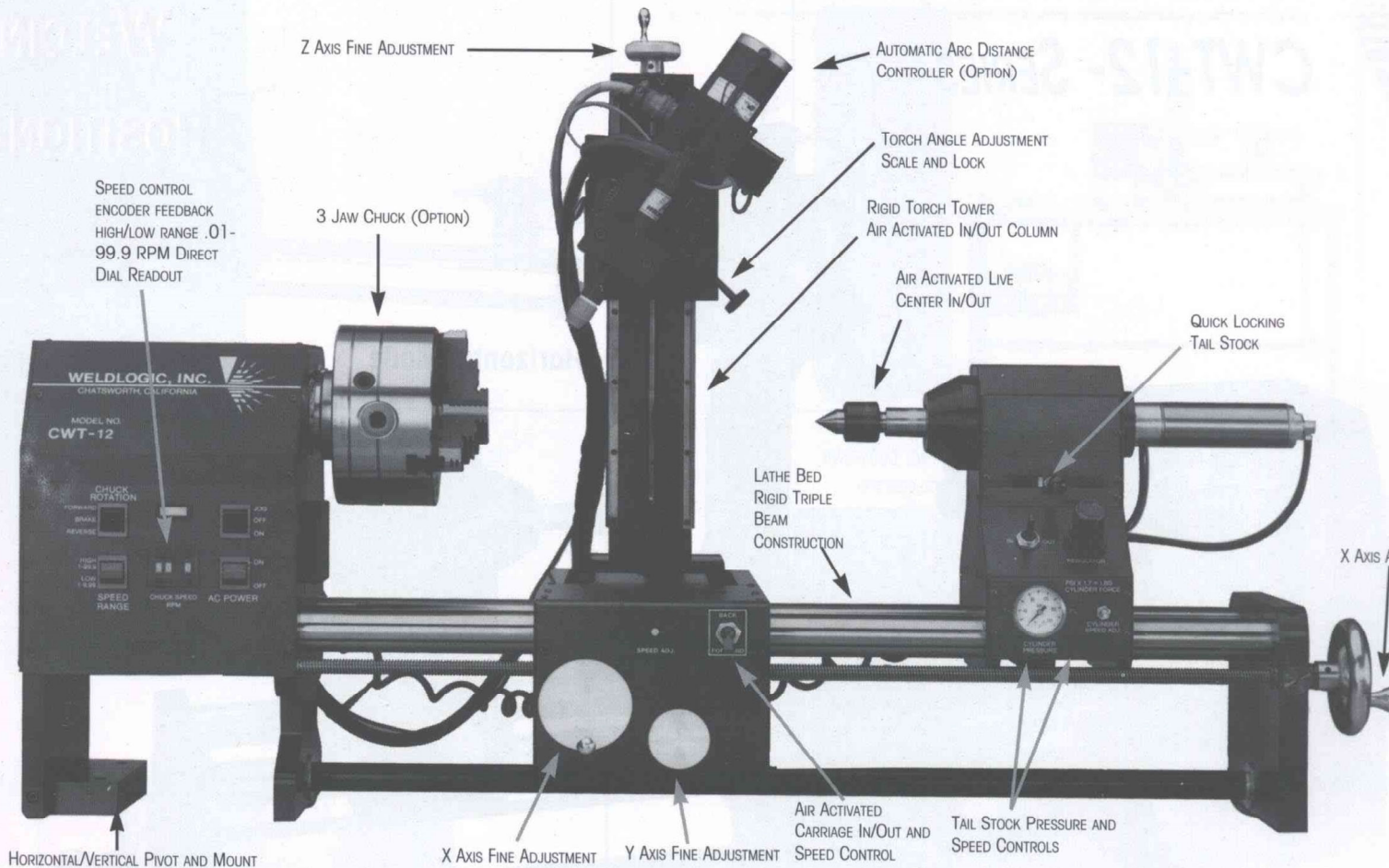

The Weldlogic CWT-12- Horizontal/ Vertical circumferential weld positioners are engineered to be a highly versatile, precision welding positioner. Our CWT wasn't adapted, but was specifically designed for precision automatic welding. Accuracy and repeatability permit circumferential, longitudinal and spot welds to be made automatically with a minimum of operator skill.

To order your CWT-12-__ Horizontal/Vertical Positioner, select the distance between centers and desired options

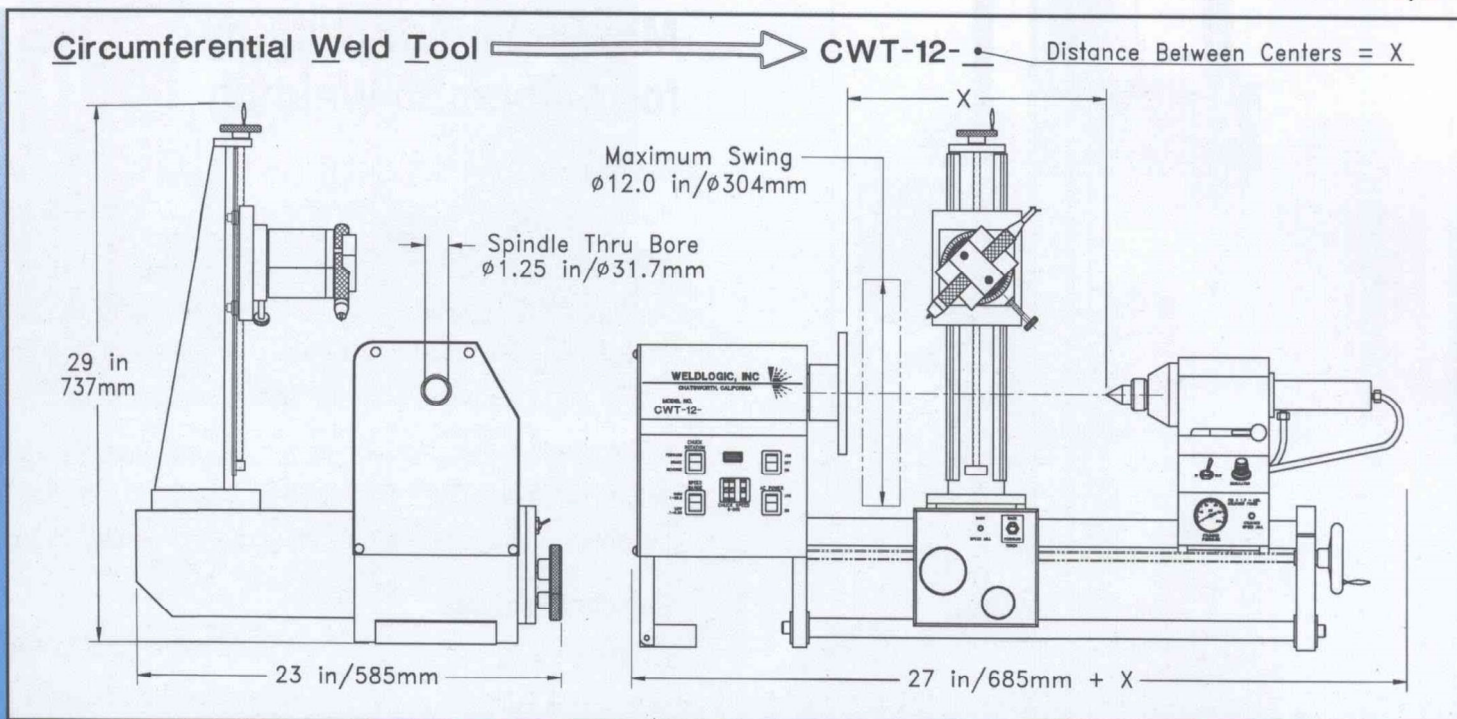

Specifications:

Note: specifications subject to change

- Input voltage 100/125 200/250 VAC
- 50/60 hz 100 VA
- Weight: 135 lbs. 63.4 kg
- Speed Range 0.01-99.9 RPM
- Speed Accuracy: 0.10% of full scale
- T.I.R.: .001 in .025 mm
- Weld Current Capacity: 300 Amps
- Tail Stock Stroke: 3.00 in 76 mm
- Tail Stock Force: 175 lbs. 778 N
- Remote 0-10v Speed Control
- Capacity 125 lbs. 56.8 kg.