

70 Series

Constant-Speed Wire Feeder 

Quick Specs



Heavy Industrial Applications

Heavy Manufacturing
Metal Fabrication
Construction
Light Manufacturing

Processes

MIG (GMAW)
Flux-Cored (FCAW)
(Gas- and Self-Shielded)

Input Power 24 VAC, 10 A, 50/60 Hz

Electrode Wire Diameter Capacity .023–5/64 in. (0.6–2.0 mm)

Wire Speed 50–780 IPM (1.3–19.8 m/min.)

Weight Single Feeder: 58 lb. (26 kg) Dual Feeder: 87 lb. (39.5 kg)



Models:
74S: Standard, basic design
74D: Digital meters
74DX: Deluxe — digital, full-feature
74 MPa: Digital, full-feature with Alumination™ Technology



Models include Bernard® Q400 MIG gun (two with D-74 models), .035/.045 drive rolls and Centerfire™ contact tips! For more options, visit MillerWelds.com/equiptoweld.

Easy access on/off switch

S-74D Model

S-74DX Model

S-74 MPa Model

10-foot, 14-pin interconnecting cord for connecting to any Miller 14-pin power source.

Trigger receptacle oriented in a downward position to reduce potential damage.

Trigger hold reduces operator fatigue by allowing the operator to make long welds without having to energize the trigger continuously.

Dual-wire feeders allow two different wire types to be available on one feeder, avoiding downtime from changing spools and drive rolls.



For MPa Plus Feeders Only! XR-AlumaPro™ Plus and XR™-Pistol Plus push-pull guns for aluminum. Comes in 15-, 25- and 35-foot lengths for extended reach with trouble-free, reliable feeding. Gun is available in either air- or water-cooled versions.

Posifeed™ Wire Drive Assembly Features

- 24 VDC high-torque, permanent-magnet motor.
- Quick-change drive rolls.
- Quick-release, calibrated drive-roll pressure adjustment arm allows drive roll change without losing spring preload setting.
- Four sealed ball bearing all-gear-driven drive-roll carriers for smooth, positive and accurate wire feed with long uninterrupted service life.
- Easy loading and threading of welding wire without having to release the drive-roll pressure arm.
- Solid-state speed control and brake circuit eliminates the need for electrical/mechanical relays and increases service life.
- Uses Miller standard 1-5/8 inch (41 mm) diameter drive rolls.
- Quick-connect for all Miller guns.
- Covered drive rolls — easy access, heavy-duty, molded composite cover over drive assembly.
- Floating positive drive systems provide trouble-free feeding on a variety of wires.



Wire feeder is warranted for 3 years, parts and labor.



Miller Electric Mfg. Co.
An ITW Company
1635 West Spencer Street
P.O. Box 1079
Appleton, WI 54912-1079 USA

Equipment Sales US and Canada
Phone: 866-931-9730
FAX: 800-637-2315
International Phone: 920-735-4554
International FAX: 920-735-4125

MillerWelds.com
  



74S, 74D and 74DX Wire Feeder Features

S-74S
Single Feeder



D-74D
Dual Feeder



S-74DX
Single Feeder



S Models (Basic 70 Series feeders)

- Wire speed control.
- Factory-set run-in control for improved arc starts.
- 24 VDC high-torque, permanent-magnet motor.
- Quick-change drive rolls.
- Quick-release, drive-roll pressure adjustment arm allows drive roll change without losing spring preload setting.
- Solid-state speed control and brake circuit for increased service life.
- Floating positive drive systems provide trouble-free feeding on a variety of wires.

D Models Add the Following Features

- Digital meters for easy viewing of the wire feed speed and voltage.
- Remote voltage control allows operator to set voltage at the wire feeder without having to go back to the power source.
- Tachometer feedback to help keep wire feed speed accurate.

DX Models Add the Following Features

- Four weld programs allow the operators to store four independent welding parameters reducing welding setup time. (Four programs available per side on dual feeder.)
- Adjustable run-in control for improved arc starts.
- Adjustable weld sequence control gives operator complete control of the welding parameters: preflow, run-in, weld time, crater, burnback and postflow.
- Welding process range control locks parameters at a set percentage of welding parameters to ensure welding procedures and quality standards are maintained on the shop floor.
- Dual schedule, trigger dual schedule and trigger program select allows operator to switch welding parameters without readjusting machine, eliminating downtime and enhancing quality.

74S, 74D and 74DX Specifications (Subject to change without notice.)



(Use with CV, DC Power Sources.)

Input Power	Electrode Wire Diameter Capacity*	Wire Speed	Dimensions		Net Weight	
			S-74 (Single Feeder)	D-74 (Dual Feeder)	S-74 (Single)	D-74 (Dual)
24 VAC, 10 A, 50/60 Hz	.023–5/64 in. (0.6–2 mm)	50–780 IPM (1.3–19.8 m/min.) Optional High-Speed Motor: 90–1440 IPM (2.3–36.6 m/min.)	H: 14 in. (356 mm) W: 12.5 in. (318 mm) D: 28 in. (711 mm)	H: 14 in. (356 mm) W: 21 in. (533 mm) D: 35 in. (889 mm)	58 lb. (26 kg)	87 lb. (39.5 kg)

*Note: When using 3/32–1/8 in. (2.4–3.2 mm) wires contact Miller Electric Mfg. Co. at 1-920-735-4505 for more information on Low-Speed options.

74S, 74D and 74DX Control Panels

S-74S and S-74D

1. Voltage Display Meter*
2. Wire Speed Display Meter*
3. Wire Feed Speed Select
4. Trigger Hold
5. Voltage Select**
6. Jog/Purge

*S-74D model only
**Optional on S-74S

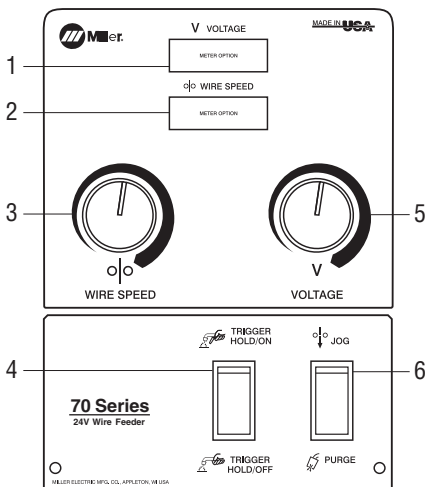

S-74DX

1. Program Display
2. Program # Select
3. Weld Sequence
4. Voltage/Time Select
5. Voltage/Time Display Meter
6. Wire Feed/Amperage Select
7. Wire Speed/Amperage Display Meter
8. Control Knob
9. Trigger Hold/Dual Schedule Control
10. Jog/Purge

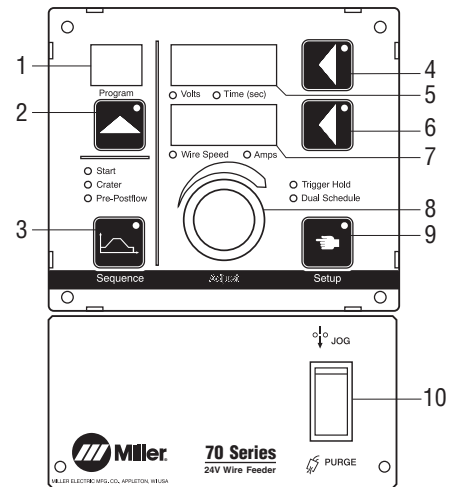

74 MPa Plus Wire Feeder Features

S-74 MPa Plus
Single Feeder



D-74 MPa Plus
Dual Feeder



MPa Plus Models have the Features of the S/D/DX Models and Add the Following

- **Alumination™** technology gives you the ability to use the extended reach of a push-pull system for consistent, versatile and dependable aluminum wire feeding. Alumination gives you the versatility to handle whatever aluminum welding job you want to tackle.
- **Synergic Pulsed MIG** operation when optimized with the Invision MPa power supplies. Provides communication between the power source, feeder and gun. As wire speed increases/decreases, the pulse parameters also increase/decrease to match the right amount of power needed.
- **Trigger schedule select** allows the operator to select the alternative schedule by quickly tapping the gun trigger when not welding. When optimized with MPa power sources the operator can also switch from MIG to Pulsed MIG.
- **Profile Pulse™** provides TIG appearance with MIG simplicity and productivity. Achieve “stacked dime” weld bead appearance without back-stepping. Profile Pulse frequency can be changed to increase or decrease the spacing between the ripple pattern to achieve the desired weld appearance.
- **Accu-Mate™** properly seats the power pin for best feeding performance and prevents Accu-Mate grooved MIG guns from sliding in the casting.

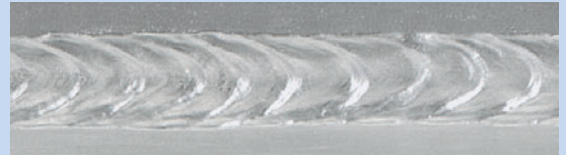

74 MPa Plus Specifications (Subject to change without notice.)

CV DC (Use with CV, DC Power Sources.)

Input Power	Electrode Wire Diameter Capacity*	Wire Speed	Dimensions		Net Weight	
			S-74 MPa Plus (Single Feeder)	D-74 MPa Plus (Dual Feeder)	S-74 MPa Plus (Single Feeder)	D-74 MPa Plus (Dual Feeder)
24 VAC, 10 A, 50/60 Hz	.023–5/64 in. (0.6–2.0 mm) .035–1/16 in. (0.9–1.6 mm) Aluminum	50–780 IPM (1.3–19.8 m/min.)	H: 14 in. (356 mm) W: 12.5 in. (318 mm) D: 28 in. (711 mm)	H: 14 in. (356 mm) W: 21 in. (533 mm) D: 35 in. (889 mm)	58 lb. (26 kg)	87 lb. (39.5 kg)

*Wire kit #230 708 is required to run 1/16 in. (1.6 mm) aluminum wire on XR-AlumaPro™ Plus guns and XR™-Pistol Plus guns.

74 MPa Plus Control Panel (D-74 MPa Plus dual feeder panel shown.)

D-74 MPa Plus

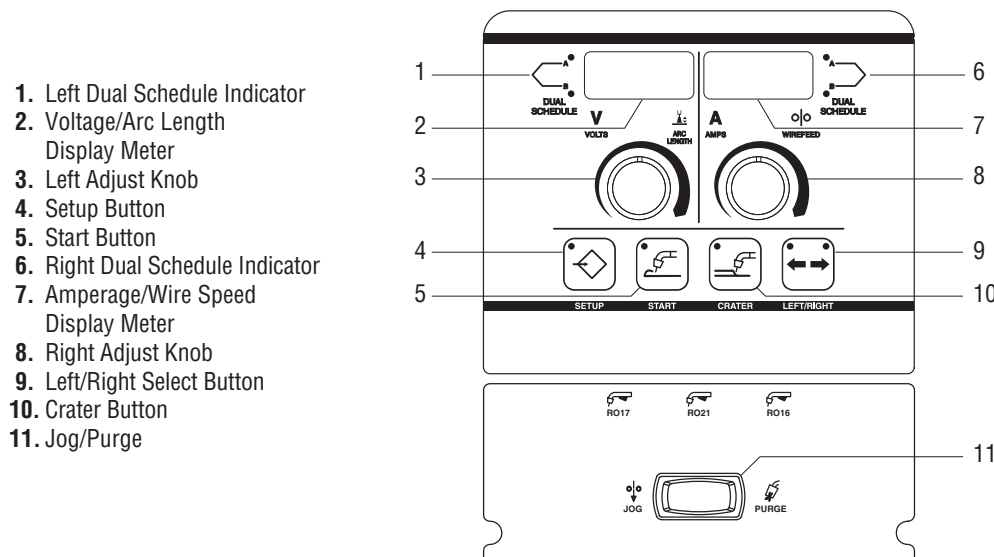

70 Series Control Box, Cables and Wire Drive Motor Assemblies

Single Remote Configuration

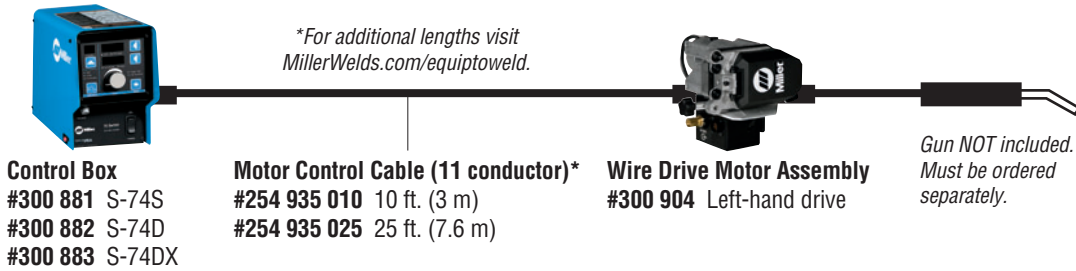

Flexible Mounting Options for Wire Drive Assembly:

Fixed automation, boom applications, or other applications that benefit from having the drive assembly located away from the control box.

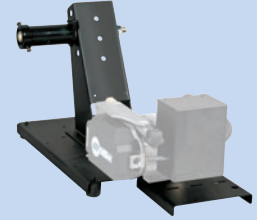

If using spooled wire you will need to order Feeder Base #195 369.

Dual Remote Configuration

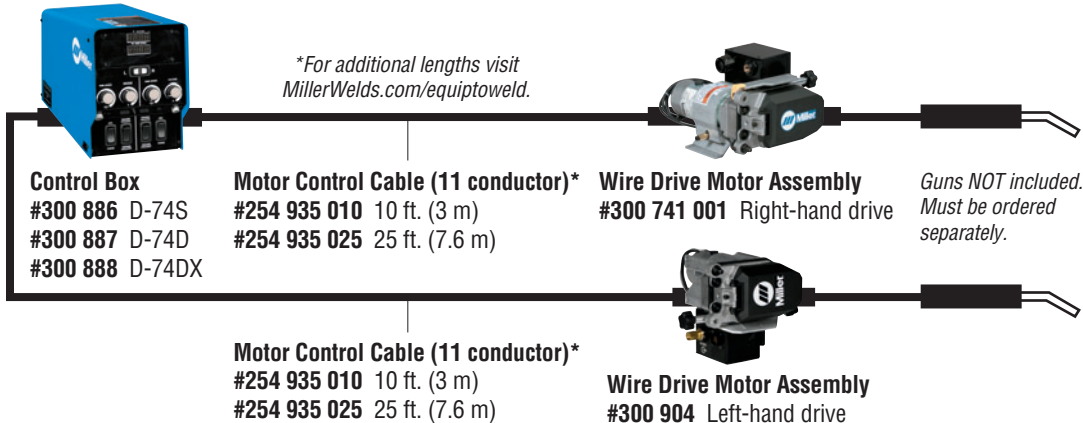

70 Series MPa Plus Control Box, Cables and Wire Drive Motor Assemblies

Single Remote Configuration

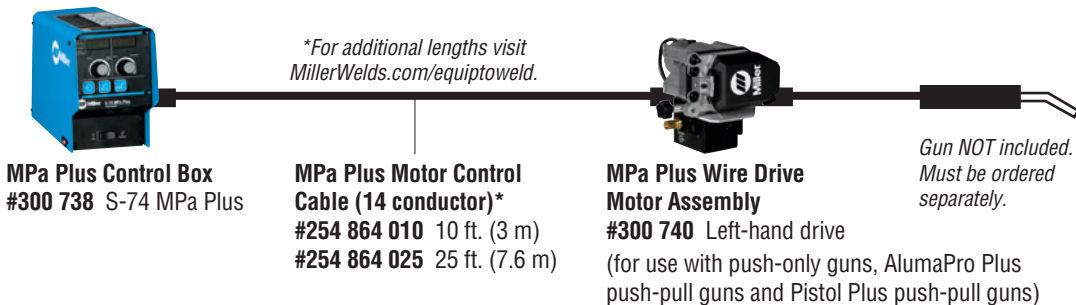

Flexible Mounting Options for Wire Drive Assembly:

Fixed automation, boom applications, or other applications that benefit from having the drive assembly located away from the control box.

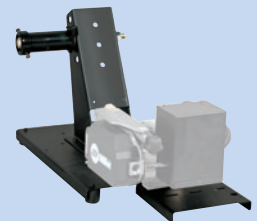

If using spooled wire you will need to order Feeder Base #195 369.

Dual Remote Configuration

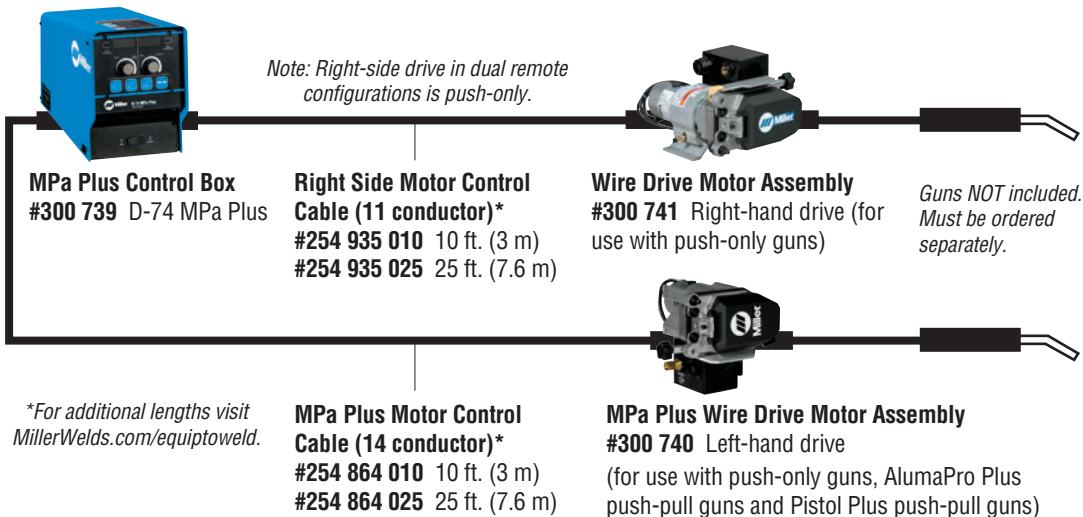





Power Source Compatibility for MPa Plus Wire Feeders

Power Source	Pulse Capable	Synergic Pulsed MIG	System Communication Enhanced Arc Control	Electronic Inductance/SharpArc	Compatibility
Invision™ 352 and 450 MPa	Yes	Yes	Yes	Yes	Optimized
XMT® 350 and 450 MPa	Yes	Yes	Yes	Yes	Best
AlumaPower™ 350 and 450 MPa	Yes (Aluminum only)	Yes (Aluminum only)	Yes	Yes	Best
XMT® 350 and 450 CC/CV	Yes (with Optima)	No	No	Yes	Better
XMT® 304 CC/CV	Yes (with Optima)	No	No	Yes	Better
Invision™ 456P	Yes (with Optima)	No	No	Yes	Better
Invision™ 456MP	Yes	No	No	Yes	Better
Invision™ 354P	Yes (with Optima)	No	No	Yes	Better
Invision™ 354MP	Yes	No	No	Yes	Better
Deltaweld® (after KF790532)	No	No	No	No	Good
Dimension™ (after KE614131)	No	No	No	No	Good

Note: Power sources not included in this list are not recommended. For specific information, please contact your local Miller® distributor.

Drive Roll Kits and Guides (Order from Miller Service Parts.)

Select drive roll kits from chart below according to type and wire size being used. Drive roll kits include four drive rolls, necessary guides and feature an anti-wear sleeve for inlet guide.

Wire Size	"V" groove for hard wire 	"U" groove for soft wire or soft-shelled cored wires 	"V" knurled for hard-shelled cored wires 	"U" clogged for extremely soft wire or soft-shelled cored wires (i.e., hard facing types) 	"U" groove for aluminum wires contains nylon guides 
.035 in. (0.9 mm)	#151 026	—	#151 052	—	#243 233
.040 in. (1.0 mm)	#161 190	—	—	—	—
.045 in. (1.1/1.2 mm)	#151 027	#151 037*	#151 053	#151 070	#243 234*
.052 in. (1.3/1.4 mm)	#151 028	#151 038	#151 054	#151 071	—
1/16 in. (1.6 mm)	#151 029	#151 039	#151 055	#151 072	#243 235
.068/.072 in. (1.8 mm)	—	—	#151 056	—	—
5/64 in. (2.0 mm)	—	#151 040	#151 057	#151 073	—
3/32 in. (2.4 mm)	—	#151 041	#151 058	#151 074	—

*Accommodates .045 and .047 (3/64 in.) wire.

Nylon Wire Guides for Feeding Aluminum Wire

Wire Size	Inlet Guide	Intermediate Guide
.035 in. (0.9 mm)	#221 912	#242 417
.047 in. (1.2 mm)	#221 912	#205 936
1/16 in. (1.6 mm)	#221 912	#205 937

Note: "U" groove drive rolls are recommended when feeding aluminum wire.

Wire Guides

Wire Size	Inlet Guide	Intermediate Guide
.023 – .040 in. (0.6 – 1.0 mm)	#221 030	#149 518
.045 – .052 in. (1.1 – 1.4 mm)	#221 030	#149 519
1/16 – 5/64 in. (1.6 – 2 mm)	#221 030	#149 520
3/32 – 7/64 in. (2.4 – 2.8 mm)	#229 919	#149 521

Genuine Miller® Options and Accessories

Remote Voltage Control

#194 988 Field Non-digital for S-74S

#194 991 Field Non-digital for D-74S



Industrial MIG 4/0 Kit with Dinse Connector #300 405

For use with XMT® 304 and 350, and Invision™ 350 MPa and 352 MPa power sources. This useful pulse-ready MIG kit can be purchased separately. Includes regulator/flowmeter with 10-foot (3 m) gas hose, 10-foot (3 m) 4/0 feeder weld cable with Dinse connector on one end and a lug on the other, 15-foot (4.6 m) work cable with Dinse connector on one end and 600-amp C-clamp on the other.



Industrial MIG 4/0 Kit #300 390

For use with Invision™ 450 MPa, XMT® 450 CC/CV and MPa, CP-302, Deltaweld, and Dimension power sources. Includes regulator/flowmeter with 10-foot (3 m) gas hose, 10-foot (3 m) 4/0 feeder weld cable with lugs, and 15-foot (4.6 m) work cable with 600-amp C-clamp.

Carrying Cart #056 301

A utility cart for the wire feeder and other miscellaneous welding supplies. Height: 34 inches (863 mm). Lower tray height: 9 inches (228 mm). Shipped disassembled.

Feeder Cart #142 382

A low-profile, creeper cart which allows the operator to easily move the feeder around the work area. Shipped disassembled.

Turntable Assembly #146 236

Allows rotation of the feeder as the operator changes work positions. Reduces strain and bending on the gun cable.

Hanging Bail (Electrically Isolated) #058 435

Used for suspending feeder over work area.

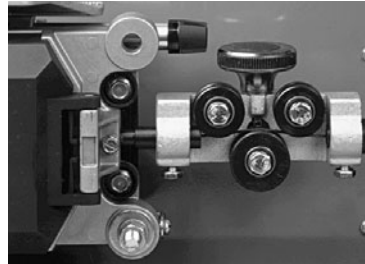

Wire Straightener

#141 580 For .035–.045 inch (0.9–1.1 mm) diameter wire.

#141 581 For 1/16–1/8 inch (1.6–3.2 mm) diameter wire.

Helps reduce the cast in wire to improve wire feeding performance and increase the service life of the gun liner and contact tip.



Spool Covers

#057 607 For S-74 and left side of D-74 models

#090 389 For right side of D-74 models
For 12-inch (305 mm) spool.

Note: Spool covers cannot be installed if the wire drive assembly is in a rotated position.



Wire Reel Assembly #108 008

For 60-pound (27 kg) coil of wire.

Reel Covers

#058 256 For S-74 and left side of D-74 models

#091 668 For right side of D-74 models

For 60-pound (27 kg) coil. Helps to protect the welding wire from dust and other contaminants.

Note: Reel covers cannot be installed if the wire drive assembly is in a rotated position.

Spool Adapter #047 141

For use with 14-pound (6.4 kg) spool of Lincoln self-shielding wire.

Extension Cables for 14-Pin Plugs to 14-Pin Sockets*

#242 208 025 25 ft. (7.6 m)

#242 208 050 50 ft. (15.2 m)

#242 208 080 80 ft. (24.4 m)

Provides 14-pin, 24 VAC, contactor and voltage control. Add to the standard 10-foot (3 m) feeder cable to extend feeder farther from power source.

**For additional lengths visit MillerWelds.com/equiptoweld.*

Dual Schedule Switches



DSS-8 #079 693

A two-position trigger switch which attaches to the gun handle and is used in place of the standard trigger for dual scheduling. *(For 74DX models only.)*



DSS-9 #071 833

A two-position slide switch which attaches to the gun handle and is used to select the desired welding condition for dual schedule purposes. The gun trigger operates as a standard gun trigger. *(For 74DX models only.)*



Swingarc™ Boom-Mounted Wire Feeders

Swingarc boom-mounted semiautomatic wire feeders bring an extra dimension of flexibility and efficiency to high-production wire welding stations. You get an effective solution that maximizes output, especially when dealing with large weldments and hard-to-reach places. See Lit. Index No. M/13.11.

For MPa Plus Wire Feeders only

Extension Cables*

- #247 831 025 25 ft. (7.6 m)
- #247 831 050 50 ft. (15.2 m)
- #247 831 080 80 ft. (24.4 m)

Eleven conductors to support contactor control and remote voltage control on all Miller electronic CV 14-pin power sources. Additional functions supported when using the MPa power sources include Synergic Pulsed MIG, and remote process select and side select capabilities.

**For additional lengths visit MillerWelds.com/equiptoweld.*



XR-Aluma-Pro™ Plus Gun

- #300 000 001 15 ft. (4.6 m), air-cooled
- #300 001 001 25 ft. (7.6 m), air-cooled
- #300 264 001 35 ft. (10.6 m), air-cooled
- #300 003 001 15 ft. (4.6 m), water-cooled
- #300 004 001 25 ft. (7.6 m), water-cooled
- #300 265 001 35 ft. (10.6 m), water-cooled

This easy-to-use and easy-to-maintain gooseneck-style MIG gun is designed for push-pull wire feed systems. Available in air- or water-cooled versions. Gun design allows for better access into tight spots.



XR™-Pistol-Plus Guns

- #300 753 15 ft. (4.6 m), air-cooled
- #300 754 25 ft. (7.6 m), air-cooled
- #300 755 35 ft. (10.6 m), air-cooled
- #300 756 15 ft. (4.6 m), water-cooled
- #300 757 25 ft. (7.6 m), water-cooled
- #300 758 35 ft. (10.6 m), water-cooled

This easy-to-use and easy-to-maintain pistol-grip MIG gun is designed for push-pull wire feed systems. Available in air- or water-cooled versions.

1/16-inch (1.6 mm) Wire Kit #230 708

Specially designed for 1/16-inch wire. Includes idler roll, head tube liner and inlet guide. Required when running 1/16-inch wires. Not included with standard XR-Aluma-Pro Plus or XR-Pistol-Plus guns.

Hardwire Liner Kit for Steel and Stainless

#198 377 For 15-, 25-, or 35-foot (4.6, 7.6 or 10.6 m) guns
Kit consists of gun head tube liner and feed cable liner. Recommend using .030–.045 inch mild steel or stainless steel electrode wire (.052- and 1/16-inch wire not recommended).

Phosphorous Bronze Liner (Optional)

- #233 999 Long Head Tube (air or water)
- #233 998 Short Head Tube (air only)

Steel Liner (Optional)

- #242 191 Short Head Tube (air only)

Ordering Information

Equipment and Options	Stock No.	Description	Qty.	Price
Single Feeders (all single feeders include one 15-ft. (4.6 m) Bernard Q400 gun and drive rolls)				
S-74S	#951 196	With standard motor		
	#951 197	With high-speed motor		
	#300 616-00-2	With CE, Euro, standard motor		
S-74D	#951 198	With standard motor		
	#951 199	With high-speed motor		
	#300 617-00-3	With CE, Euro, standard motor		
	#300 617-00-4	With CE, Euro, high-speed motor		
S-74DX	#951 200	With standard motor		
	#951 201	With high-speed motor		
	#951 202	With low-speed motor		
	#300 618-00-3	With CE, Euro, standard motor		
	#300 618-00-4	With CE, Euro, high-speed motor		
S-74 MPa Plus (Order XR-Aluma-Pro Plus or XR-Pistol Plus and U-groove drive rolls separately)	#951 291	With standard motor, optimized for MPa power sources with push-pull capability		
Dual Feeders (all dual feeders include two 15-ft. (4.6 m) Bernard Q400 guns and drive rolls)				
D-74S	#951 203	With standard motor		
	#300 619-00-1	With CE, Euro, standard motor		
D-74D	#951 204	With standard motor		
	#951 205	With high-speed motor		
	#300 620-00-2	With CE, Euro, standard motor		
	#300 620-00-3	With CE, Euro, high-speed motor		
D-74DX	#951 206	With standard motor		
	#951 207	With high-speed motor		
	#300 621-00-2	With CE, Euro, standard motor		
	#300 621-00-3	With CE, Euro, high-speed motor		
D-74 MPa Plus (Order XR-Aluma-Pro Plus or XR-Pistol Plus and U-groove drive rolls separately)	#951 292	With standard motor, optimized for MPa power sources with push-pull capability		
Remote Voltage Control	#194 988 #194 991	Field. Non-digital control (S-74S model only) Field. Non-digital control (D-74S model only)		
Remote Configurations		See page 4		
Replacement Gun and Consumables				
Bernard® Q400	#Q4015AE8EM	400 A, 15 ft. (4.6 m)		
XR-Aluma-Pro™ Plus and XR™-Pistol Plus		For MPa Plus wire feeders only. See page 7		
Centerfire™ consumables				
Power Sources				
Invision™ 352 MPa and 450 MPa		See Lit. Index No. DC/23.6		
XMT® MPa Series and 304/350/450 CC/CV		See Lit. Index No. DC/18.84, DC/18.8 and DC/18.83		
CP-302 and Deltaweld® Series		See Lit. Index No. DC/13.0 and DC/16.2		
Dimension™ Series		See Lit. Index No. DC/19.2		
Accessories				
Industrial MIG 4/0 Kits		See page 6		
Carrying Cart	#056 301			
Feeder Cart	#142 382			
Turntable Assembly	#146 236			
Hanging Bail	#058 435	Electrically isolated		
Wire Straightener		See page 6		
Spool Covers		See page 6		
Wire Reel Assembly	#108 008			
Reel Covers		See page 6		
Spool Adapter	#047 141			
Extension Cables		See pages 6 and 7		
Dual Schedule Switches		See page 7		
Swingarc™ Boom-Mounted Wire Feeders		See Lit. Index No. M/13.11		

Date:

Total Quoted Price:

Distributed by:

