



• PT-1000

POSITIONER

Compact / Reliable / High Quality

POSITIONER

With proper fixture, a welding positioner grips and rotates the workpiece setting up ergonomic working posture during welding, machining and assembly of workpieces for the operator and providing faster and more efficient process.

ProArc PT series welding positioners allow steel fabrication shops operator to position the jobs for 'downhand' position in the shortest possible time, without the use of cranes and manpower. The constructions of ProArc positioners provide safe, long-life operation and trouble-free service.



• PT-500



• PT-103



• PT-203

Features

- Capacities range from 100 to 20,000 kilograms 360° degree rotation, 135° degree tilts on all models
 - High frequency protected
 - Machined "T" slots table with pilot and through hole
 - High quality worm gear reducers for smooth operation and minimal backlash
 - Free maintenance grounding system.
 - AD type adjustable table height option available.
 - Standard forward/reverse rotation and variable speed control
-

POSITIONER

Optional accessories

- Current brush with higher amperage capacity
- Grippers
- Servo motor for rotational axis
- Variable speed foot control



• PT-204

CB-102 / CB-102D

Digital controller with reference function for 100kg, 200kg positioner



CB-102D

CB-500

Advanced ServoArc controller



AD type

Adjustable height positioner



PG-150

3-Jaw gripper
OD 4 - 150 mm



PG-450L

3-Jaw gripper
OD 4 - 450 mm



PG-500

3-Jaw gripper
OD 4 - 500 mm

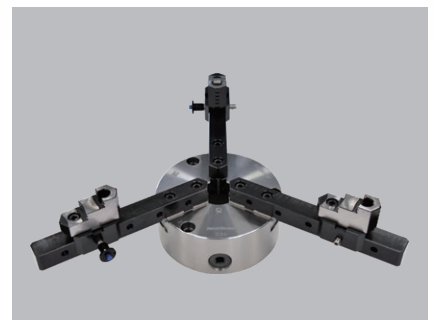

POSITIONER

Specification

Model	Unit	PT-103(4)	PT-203(4)	PT-500(M)	PT-1000	PT-2000	
Power input	~	1Ø 100~240VAC 50/60Hz			1Ø 220VAC 50/60Hz		
Capacity	kg	100 / 60	200 / 130	500	1,000	2,000	
Rated center of gravity	mm				100	300	300
Rated eccentricity	mm	Please refer to ※3			100	200	300
Rotation speed	rpm	Please refer to ※3			0.12 ~ 2	0.05 ~ 1	0.05 ~ 0.8
Welding timer	sec	0 ~ 60	0 ~ 60	0 ~ 60			
Tilt range	deg	0 ~ 120°	0 ~ 120°	0 ~ 135°	0 ~ 135°	0 ~ 135°	
Earthing	amp	300	300	300	300	600	
Overall length (A)	mm	460	460	750	1,100	1,380	
Overall width (B)	mm	315	315	650	930	1,200	
Overall height (C)	mm	340	340	620	800	1,036	
Center to floor (D) (AD type)	mm	250	250	540 (540~915)	700 (700~1,075)	900 (900~1,300)	
Table dimension (E)	mm	320	320	450	600	800	
Through hole	mm	Ø22	Ø22	Ø25	Ø26	Ø35	
Table slot bolt size		M10	M10	M12	M12	M16	
Weight	kg	35	37	135	285	500	

※1 Digital type (PT-104, PT-204)

※2 Manual Tilt (PT-500M)

※3 Please refer to E.Z.Arc catalogue

Dimensions

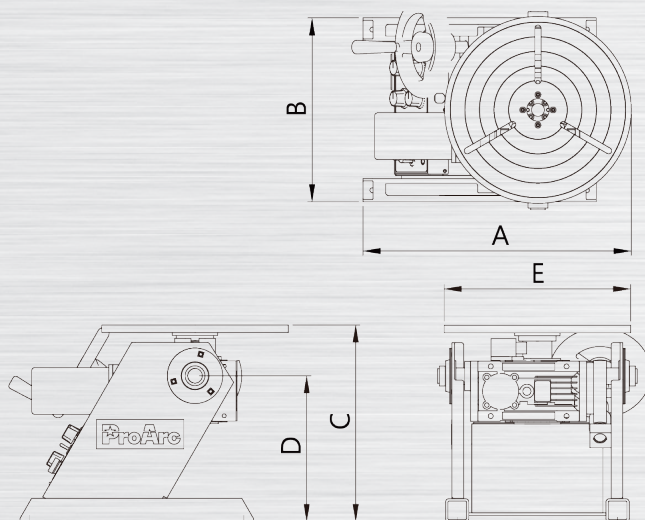

Specification

Model	Unit	PT-3000	PT-5000	PT-10K	PT-15K	PT-20K	PT-25K
Power input	~	3Ø 220VAC 50/60Hz					
Capacity	kg	3,000	5,000	10,000	15,000	20,000	25,000
Rated center of gravity	mm	300	300	300	300	300	300
Rated eccentricity	mm	200	200	300	300	300	200
Rotation speed	rpm	0.05 ~ 0.8	0.04 ~ 0.8	0.02 ~ 0.5	0.01 ~ 0.25	0.01 ~ 0.25	0.01 ~ 0.25
Tilt range	deg	0 ~ 135°	0 ~ 135°	0 ~ 135°	0 ~ 135°	0 ~ 135°	0 ~ 135°
Earthing	amp	600	600	1,200	1,200	1,200	1,200
Overall length (A)	mm	1,540	1,800	2,450	2,720	3,050	3,350
Overall width (B)	mm	1,310	1,470	1,800	2,000	2,250	2,500
Overall height (C)	mm	1,140	1,250	1,460	1,630	1,785	1,785
Center to floor (D) (AD type)	mm	1,000 (1,000~1,500)	1,100 (1,100~1,800)	1,250 (1,250~2,050)	1,400 (1,400~2,400)	1,530 (1,530~2,530)	1,530 (1,530~2,530)
Table dimension (E)	mm	1,000	1,200	1,500x1,500	1,750x1,750	2,000x2,000	2,000x2,000
Through hole	mm	Ø40	Ø40	Ø50	Ø50	Ø50	Ø50
Table slot bolt size		M20	M24	M30	M30	M30	M30
Weight	kg	1,050	1,590	4,200	5,330	5,800	7,500

※ 1 Digital type (PT-104, PT-204)

※ 2 Manual Tilt (PT-500M)

※ 3 Please refer to E.Z.Arc catalogue

Dimensions

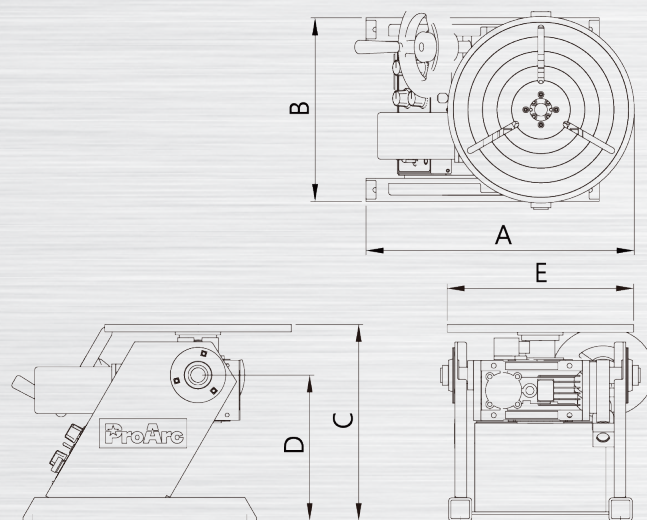

Westermans International Ltd

Unit 4 Midland Distribution Centre

Markfield Road, Groby, Leicestershire, LE6 0FS

Tel+44(0) 116 2696941

Web:www.westermans.com

E-mail:welding@westermans.com